

# 7/8"孔式自由组装连接器

## MKP5-PG11

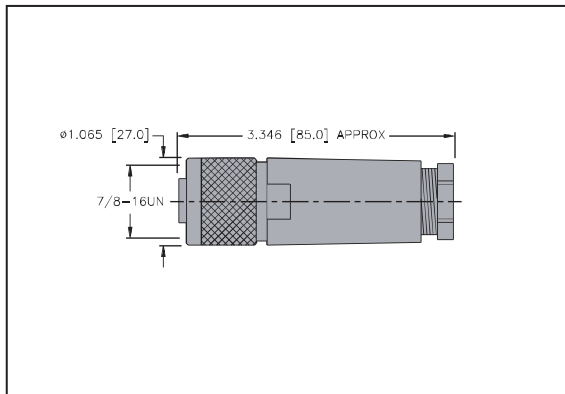

- 7/8"，直头孔型，5芯
- 适用于电源连接
- 防护等级：IP67
- 塑料外壳

### 技术参数

#### 电气参数

额定电压	10... 30VDC
额定电流	9A
绝缘阻抗	≥10 <sup>9</sup> Ω
温度范围	-40... 85°C
电缆直径 [PG11]	8... 10mm
锁紧螺母	Al-EL0X
触点	CuZn-NA
连接类型	螺钉连接
插件把手	PA
密封圈	Viton (FPM) 塑料
防护等级	IP67, 仅在连接状态下

### 接线图

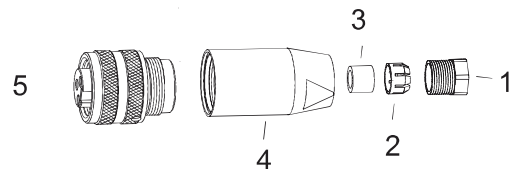
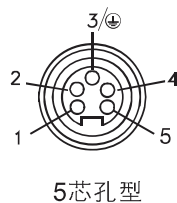

- 1 = 紧固螺母
- 2 = 卡簧
- 3 = 密封圈
- 4 = 外壳
- 5 = 孔式插芯

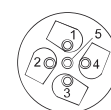

内部电缆连接  
(螺钉连接)